

CE Plus Series: 24 kW, 27 kW, 36 kW | NEMA 4/4X

Specifications

Model	CE Plus 24 kW, CE Plus 27 kW, CE Plus 36 kW
Phase	3-phase
Inlet/outlet pipe connection	3/4" female NPT
Heat exchanger material	316L stainless steel
Enclosure rating	NEMA 4 shown, NEMA 4X available
Operating pressure range	4-145 psi (0.28-10 bar)
Maximum temperature output	180 °F (82 °C)
Temperature adjustment range	60-180 °F (16-82 °C)
Temperature adjustment increment	1 °F (1 °C)
Number of heating elements	6
Minimum activation flow	0.75 gpm (2.8 l/m) for DN 10 flowmeter 1.25 gpm (4.7 l/m) for DN 15 flowmeter
Maximum flow at 60 psi	10.6 gpm (40.1 l/m) for DN 10 flowmeter 13.2 gpm (50 l/m) for DN 15 flowmeter

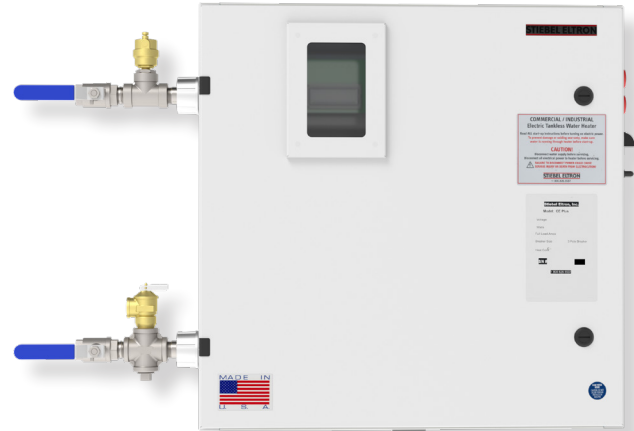

Model	Part Number	Voltage	Phase	kW	Amps	3P Breaker Size (A)	Temperature Rise °F				
							1 gpm	2 gpm	3 gpm	5 gpm	10 gpm
CE Plus 24 kW	CEPLUS-024-208	208	3-phase delta	22.53	62.55	70	>100	77	51	31	15
	CEPLUS-024-240	240	3-phase delta	25.00	60.14	70	>100	85	57	34	17
	CEPLUS-024-480	480	3-phase delta	25.00	30.07	35	>100	85	57	34	17
	CEPLUS-024-575	575	3-phase delta	24.00	24.10	30	>100	82	55	33	16
CE Plus 27 kW	CEPLUS-027-208	208	3-phase delta	27.04	75.06	80	>100	92	62	37	18
	CEPLUS-027-240	240	3-phase delta	27.02	65.01	80	>100	92	62	37	18
	CEPLUS-027-480	480	3-phase delta	27.02	32.51	40	>100	92	62	37	18
CE Plus 36 kW	CEPLUS-036-208	208	3-phase delta	36.00	99.93	110	>100	>100	82	49	25
	CEPLUS-036-240	240	3-phase delta	36.00	86.60	100	>100	>100	82	49	25
	CEPLUS-036-480	480	3-phase delta	36.00	43.30	50	>100	>100	82	49	25
	CEPLUS-036-575	575	3-phase delta	36.00	36.15	40	>100	>100	82	49	25



Certified to ANSI/UL Std. 499
Conforms to CAN/CSA
Std. C22.2 No.88



6 years against leakage /
2 years against defects in
workmanship & materials

rev. 4.2024 Due to our continuous process of engineering and technological advancement, specifications may change without notice.

Dimensions

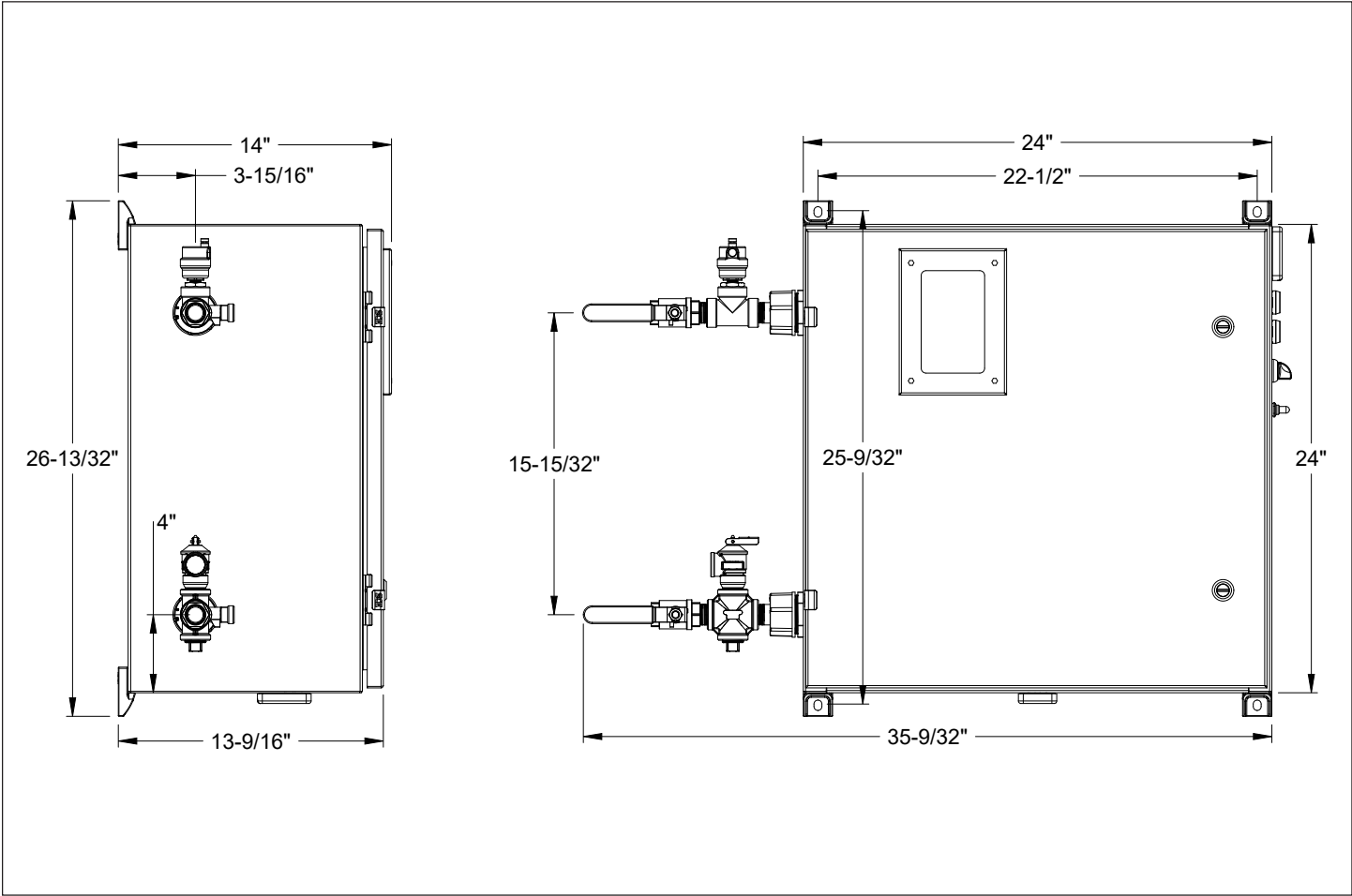

Dimensions for optional legs

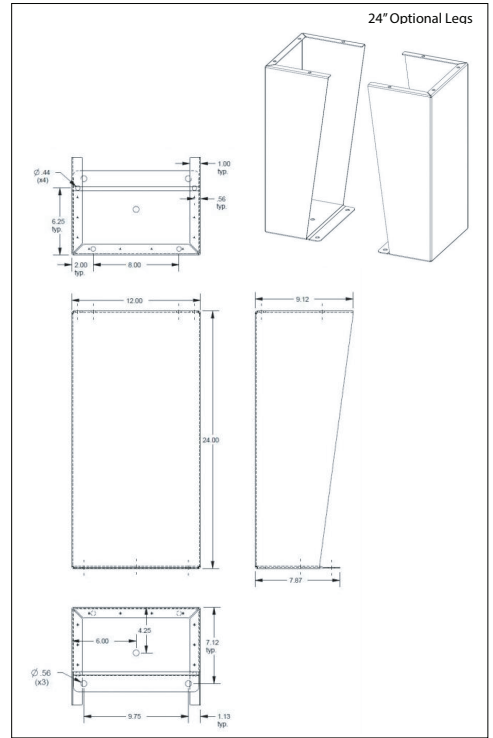
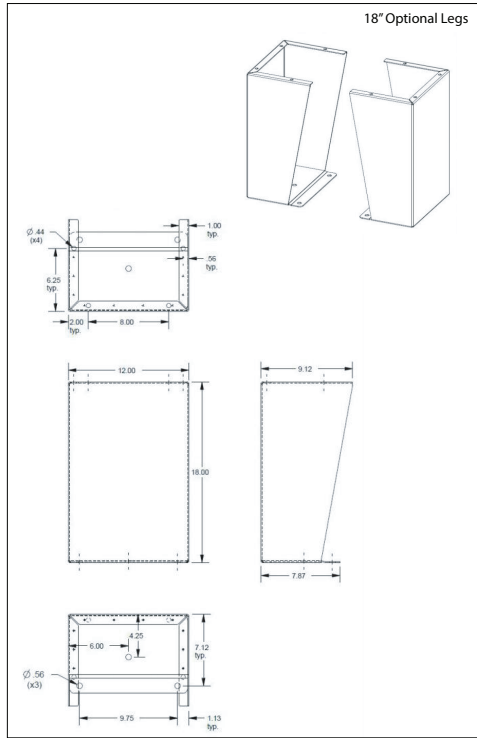
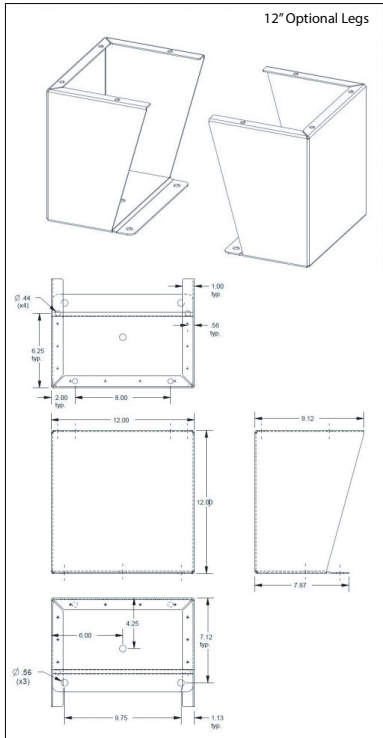

rev. 4.2024 | Due to our continuous process of engineering and technological advancement, specifications may change without notice.

Temperature Rise vs. Flow Rate

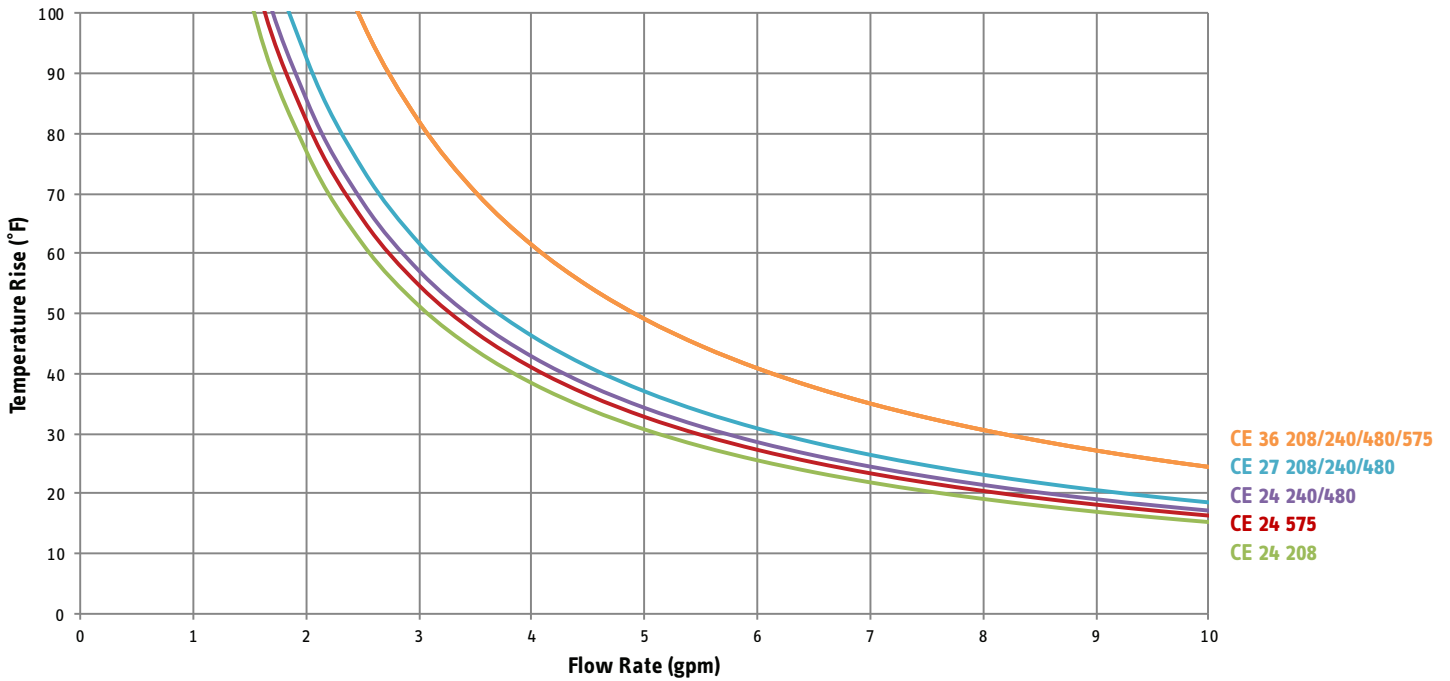

Pressure Drop vs. Flow Rate

