

OPERATION AND INSTALLATION

Buffer tank

- » SBP 200 E
- » SBP 400 E

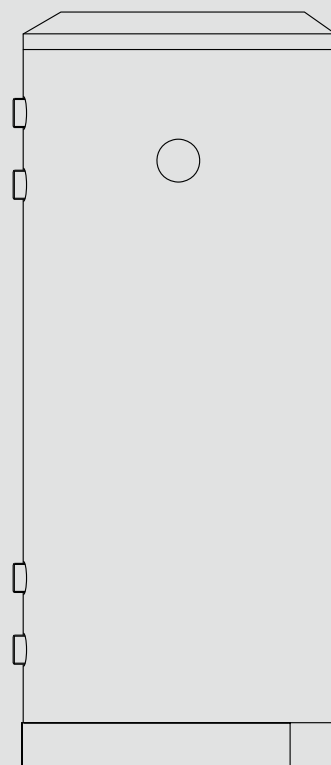

STIEBEL ELTRON

OPERATION

1. **General information** _____ 2
 1.1 Safety instructions _____ 2
 1.2 Other symbols in this documentation _____ 2
 1.3 Units of measurement _____ 3
 2. **Safety** _____ 3
 2.1 Intended use _____ 3
 3. **Appliance description** _____ 3
 4. **Cleaning, care and maintenance** _____ 3
 5. **Troubleshooting** _____ 3

INSTALLATION

6. **Safety** _____ 3
 6.1 General safety instructions _____ 3
 6.2 Instructions, standards and regulations _____ 3
 7. **Appliance description** _____ 3
 7.1 Standard delivery _____ 3
 8. **Installation** _____ 3
 8.1 Installation site _____ 3
 8.2 Releasing the transport lock _____ 4
 8.3 Transportation to the installation site _____ 4
 8.4 Positioning the appliance _____ 5
 8.5 Heating water connection _____ 5
 8.6 Sensor installation _____ 5
 9. **Commissioning** _____ 6
 9.1 Oxygen diffusion _____ 6
 9.2 Appliance handover _____ 6
 10. **Appliance shutdown** _____ 6
 11. **Maintenance** _____ 6
 11.1 Draining the appliance _____ 6
 12. **Specification** _____ 7
 12.1 Dimensions and connections _____ 7
 12.2 Data table _____ 8

OPERATION

1. General information

The chapter "Operation" is intended for appliance users and qualified contractors.

The chapter "Installation" is intended for qualified contractors.



Note
 Read these instructions carefully before using the appliance and retain them for future reference.
 Pass on the instructions to a new user if required.

1.1 Safety instructions

1.1.1 Structure of safety instructions



KEYWORD Type of risk
 Here, possible consequences are listed that may result from failure to observe the safety instructions.
 ► Steps to prevent the risk are listed.

1.1.2 Symbols, type of risk

Symbol	Type of risk
	Electrocution
	Burns (burns, scalding)

1.1.3 Keywords

KEYWORD	Meaning
DANGER	Failure to observe this information will result in serious injury or death.
WARNING	Failure to observe this information may result in serious injury or death.
CAUTION	Failure to observe this information may result in non-serious or minor injury.

1.2 Other symbols in this documentation



Note
 General information is identified by the adjacent symbol.
 ► Read these texts carefully.

Symbol	Meaning
	Material losses (appliance damage, consequential losses and environmental pollution)
	Appliance disposal

► This symbol indicates that you have to do something. The action you need to take is described step by step.

1.3 Units of measurement



Note

All measurements are in inches unless stated otherwise.

2. Safety

2.1 Intended use

The appliance is designed to store and heat heating water.

The appliance is intended for the seasonal storage (around 5 months at a room temperature of 75 °F (24 °C) and relative humidity of 40 %) of water cooled to 45 °F (7 °C). Constant cooling operation with water below 52 °F (11 °C) is not permissible.

Any other or additional use is regarded as inappropriate, in particular any usage with alternative storage media. Observation of these instructions and of the instructions for any accessories used is also part of the correct use of this appliance.

3. Appliance description

This appliance is designed to extend the operating time of the heat generator and to bridge power-OFF periods. It also enables hydraulic separation of the liquid flowing in the heat generating circuit and the heating circuit.

A threaded immersion heater can be installed to boost the temperature of the heating water.

The appliance is equipped with complete thermal insulation to protect against the formation of condensate.

4. Cleaning, care and maintenance

- ▶ Never use abrasive or corrosive cleaning agents. A damp cloth is sufficient for cleaning the appliance.

5. Troubleshooting

Call your qualified contractor. To facilitate and speed up your enquiry, please provide the serial number from the type plate (no. 000000-0000-000000):

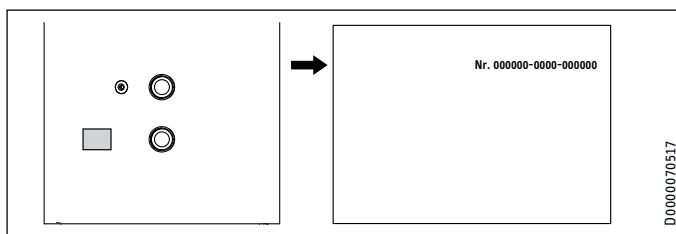

INSTALLATION

6. Safety

Only a qualified contractor should carry out installation, commissioning, maintenance and repair of the appliance.

6.1 General safety instructions

We guarantee trouble-free function and operational reliability only if original accessories and spare parts intended for the appliance are used.

6.2 Instructions, standards and regulations



Note

Observe all applicable national and regional regulations and instructions.

7. Appliance description

7.1 Standard delivery

The following are delivered with the appliance:

- 3 cover sleeves
- 4 plugs

8. Installation

8.1 Installation site

Install the appliance near the heat generator in a room free from the risk of frost.

Ensure the floor has a sufficient load bearing capacity (see chapter "Specification / Data table").

Observe the room height (see chapter "Specification / Data table").

INSTALLATION

Installation

8.1.1 Minimum clearances

The minimum side clearances specified enable accessories to be installed.

The minimum side clearances can be swapped between left and right.

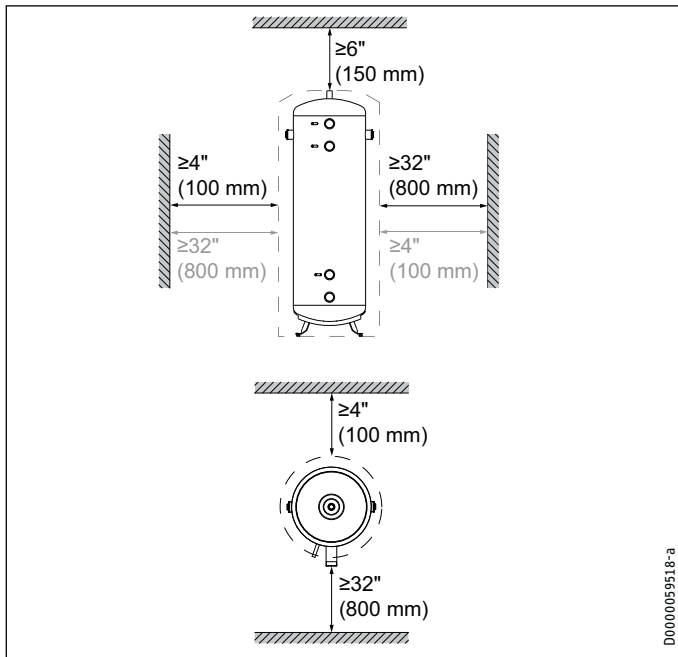

- ▶ Maintain the minimum clearances.

8.2 Releasing the transport lock

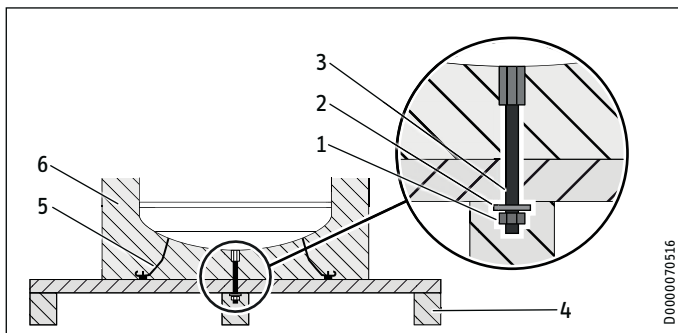

- 1 Nut
- 2 Washer
- 3 Threaded pin
- 4 Shipping pallet
- 5 Adjustable feet
- 6 Thermal insulation

- ▶ Remove the packaging material from the tank. The corrugated card board serves as padding for the following steps.
- ▶ Tilt the appliance together with the shipping pallet onto its side and place it on the corrugated card board or another suitable underlay.
- ▶ Undo and remove the nut and washer on the underside of the shipping pallet.
- ▶ Pull the shipping pallet away from the appliance. Lay the appliance down carefully on the padding while doing so.
- ▶ Undo and remove the threaded pin on the underside of the appliance.

- ▶ Press one of the supplied plugs into the now exposed aperture in the thermal insulation.

This appliance comes with adjustable feet as standard.

- ▶ Wind the adjustable feet out far enough so they protrude beyond the thermal insulation.
- ▶ Stand the appliance upright.

8.3 Transportation to the installation site



Material losses

We recommend removing the tank jacket for transportation to the installation site to prevent it from becoming dirty or damaged (see chapter "Removing the tank jacket").

8.3.1 Removing the tank jacket

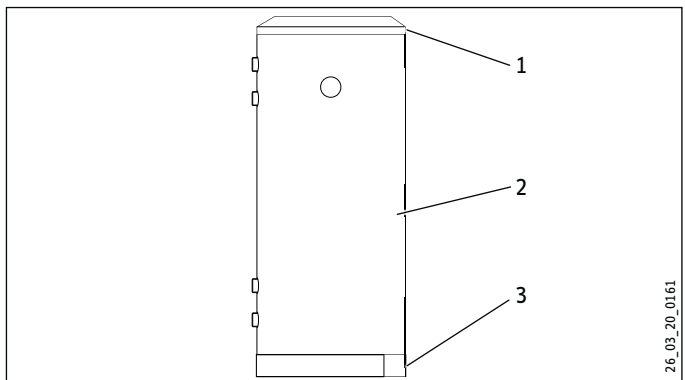

- 1 Cover
- 2 Tank jacket
- 3 Plinth trim

- ▶ First remove the cover and then the plinth trim.
- ▶ Remove the tank jacket.

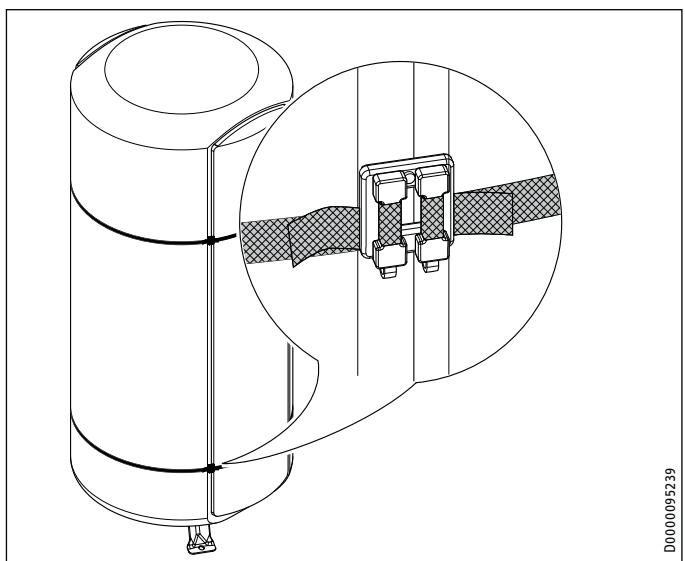

- ▶ Ensure that the closures are positioned in the joint between a side insulation segment and the thermal insulation of the tank.

Installation

8.4 Positioning the appliance

This appliance comes with adjustable feet as standard.

- ▶ The adjustable feet can be extended outwards to compensate for any unevenness in the floor.

8.5 Heating water connection



Note

Connect the hydraulic connections with flat gaskets.

8.5.1 Fitting the drain valve

- ▶ To facilitate maintenance work on the appliance, fit a drain valve (not included in standard delivery) in the lowest connection line.

8.5.2 Fitting the air vent valve



Material losses

Before filling the appliance, fit an air vent valve to prevent water damage.

8.6 Sensor installation

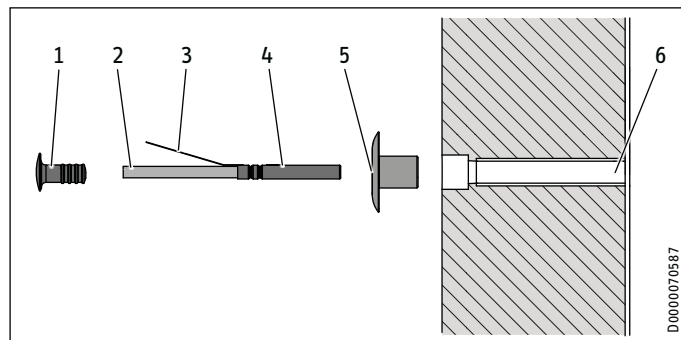

- | | |
|------------------|----------------------|
| 1 Plug | 4 Temperature sensor |
| 2 Sensor lead | 5 Cover sleeve |
| 3 Spring shackle | 6 Sensor well |

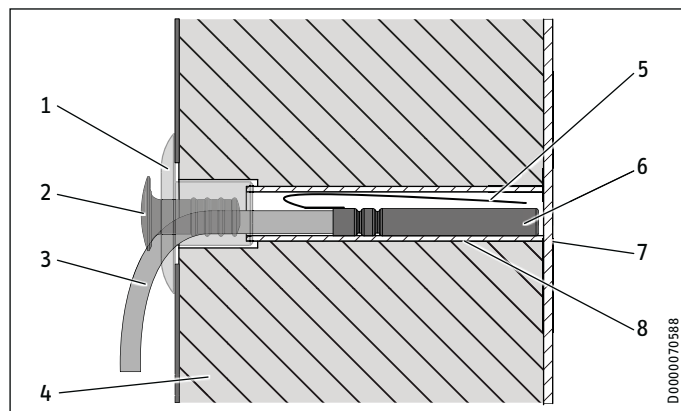

- | | |
|----------------------|----------------------|
| 1 Cover sleeve | 5 Spring shackle |
| 2 Plug | 6 Temperature sensor |
| 3 Sensor lead | 7 Tank wall |
| 4 Thermal insulation | 8 Sensor well |

- ▶ Plug the cover sleeve into the sensor well.
- ▶ Bend the temperature sensor spring shackle over forwards.
- ▶ Route the temperature sensor through the cover sleeve and push it into the sensor well, as far as the tank wall.
- ▶ To secure the sensor lead, press the plug into the cover sleeve as far as it will go. In doing so, route the sensor lead downwards out of the sensor well.



Note

If no temperature sensor is being used, seal the sensor well by pressing the plug fully into the cover sleeve to act as a dummy plug.

9. Commissioning



Material losses

If a threaded immersion heater has been installed, the maximum temperature of the DHW tank may need to be limited. This prevents the temperature limiters of the installed accessories from responding.



Material losses

A safety valve is required.

- ▶ Fill and vent the appliance.
- ▶ Fit and check accessories as required.

9.1 Oxygen diffusion



Material losses

Avoid open vented heating systems and underfloor heating systems with plastic pipes which are permeable to oxygen.

In underfloor heating systems with plastic pipes that are permeable to oxygen and in open vented heating systems, oxygen diffusion may lead to corrosion on the steel components of the heating system (e.g. on the indirect coil of the DHW tank, on buffer tanks, steel radiators or steel pipes).



Material losses

The products of corrosion (e.g. rusty sludge) can settle in the heating system components, which may result in a lower output or fault shutdowns due to reduced cross-sections.



Material losses

Avoid open vented solar thermal systems and plastic pipes which are permeable to oxygen.

With plastic pipes that are permeable to oxygen, oxygen diffusion can cause corrosion on the steel components of the solar thermal system (e.g. on the indirect coil of the DHW tank).

9.2 Appliance handover

- ▶ Explain the appliance function to users and familiarise them with its operation.
- ▶ Make the user aware of potential dangers, especially the risk of scalding.
- ▶ Hand over these instructions.

10. Appliance shutdown

- ▶ Disconnect any electrical accessories installed from the mains at the fuse/MCB in the fuse box.
- ▶ Drain the appliance. See chapter "Maintenance / Draining the appliance".

11. Maintenance



WARNING Electrocutation

Carry out all electrical connection and installation work in accordance with relevant regulations.

If you need to drain the appliance, observe chapter "Draining the appliance".

11.1 Draining the appliance



WARNING Burns

Hot water may escape during draining.

If the appliance needs to be drained for maintenance or to protect the whole installation from frost, proceed as follows:

- ▶ Close the shut-off valves in the inlet lines.
- ▶ Connect a drain line to the drain valve (not included in standard delivery).
- ▶ Open the drain valve.
- ▶ When the excess pressure has been released, open the ventilation facility (see chapter "Specification / Dimensions and connections") and drain the appliance.

12. Specification

12.1 Dimensions and connections

SBP 200 E

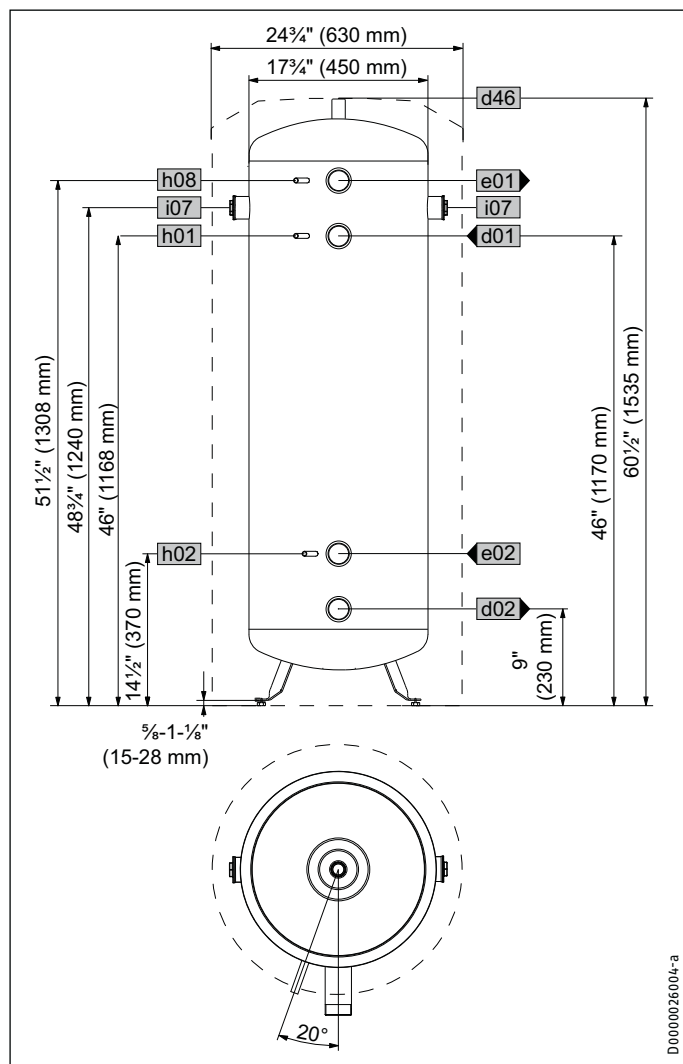

SBP 200 E			
d01	Heat pump flow	Male thread	G 2 A
d02	Heat pump return	Male thread	G 2 A
d46	Ventilation	Female thread	G 3/4
e01	Heating flow	Male thread	G 2 A
e02	Heating return	Male thread	G 2 A
h01	Sensor heat pump flow	Diameter	3/8" (9.5 mm)
h02	Sensor heat pump return	Diameter	3/8" (9.5 mm)
h08	Sensor heat pump cooling	Diameter	3/8" (9.5 mm)
i07	Electric emergency/booster heater	Female thread	G 1 1/2

*An adapter kit (part no. 556240) to 1 1/4" NPT threads is included with the SBP 200 E

SBP 400 E

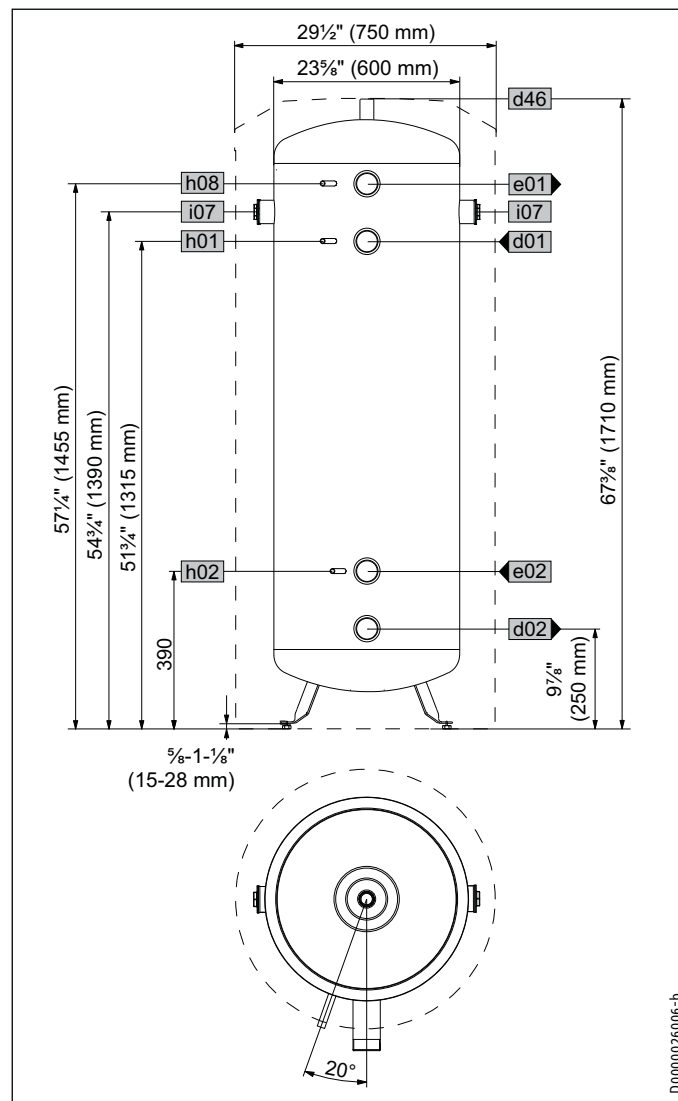

SBP 400 E			
d01	Heat pump flow	Male thread	G 2 A
d02	Heat pump return	Male thread	G 2 A
d46	Ventilation	Female thread	G 3/4
e01	Heating flow	Male thread	G 2 A
e02	Heating return	Male thread	G 2 A
h01	Sensor heat pump flow	Diameter	3/8" (9.5 mm)
h02	Sensor heat pump return	Diameter	3/8" (9.5 mm)
h08	Sensor heat pump cooling	Diameter	3/8" (9.5 mm)
i07	Electric emergency/booster heater	Female thread	G 1 1/2

*An adapter kit (part no. 556240) to 1 1/4" NPT threads is included with the SBP 400 E

INSTALLATION Specification

12.2 Data table

	SBP 200 E	SBP 400 E
	185458	220824
Hydraulic data		
Rated capacity	54.7 gal (207 l)	109.6 gal (415 l)
Application limits		
Max. permissible pressure	43.5 psi (0.3 MPa)	43.5 psi (0.3 MPa)
Test pressure	65.3 psi (0.45 MPa)	65.3 psi (0.45 MPa)
Maximum charge / discharge flow rate	7 gpm (26.5 l/m)	13.6 gpm (51.5 l/m)
Max. permissible temperature	203°F (95°C)	203°F (95°C)
Energy data		
Standby energy consumption/24 h at 149°F (65°C)	3750 BTU (1.1 kWh)	5460 BTU (1.6 kWh)
Dimensions		
Height	60½" (1535 mm)	67¾" (1710 mm)
Diameter	24¾" (630 mm)	29½" (750 mm)
Height of unit when tilted	65" (1650 mm)	71" (1800 mm)
Weights		
Weight (wet)	569 lbs (258 kg)	1060 lbs (481 kg)
Weight (dry)	128 lbs (58 kg)	179 lbs (81 kg)

Environment and recycling

- ▶ Dispose of the appliances and materials after use in accordance with national regulations.



- ▶ If a crossed-out waste bin is pictured on the appliance, take the appliance to your local waste and recycling centre or nearest retail take-back point for reuse and recycling.



This document is made of recyclable paper.

- ▶ Dispose of the document at the end of the appliance's life cycle in accordance with national regulations.

SBP Buffer Tanks

ALL SBP 100 Plus, SBP 200 E & SBP 400 E Models

LIMITED WARRANTY

Subject to the terms and conditions set forth in this limited lifetime warranty, Stiebel Eltron, Inc. (the "Manufacturer") hereby warrants to the original purchaser (the "Owner") that each storage tank (the "Tank") shall be free from defects in the Manufacturer's materials or workmanship for a period of:

- 1. (7 Years) for tank
- 2. (7 Years) for part(s) not referenced above

As Owner's sole and exclusive remedy for the above warranty, Manufacturer shall, at the Manufacturer's discretion, either factory repair or replace the defective Tank with a replacement unit or part(s) with comparable operating features. Manufacturer's maximum liability under all circumstances shall be limited to the Owner's purchase price for the Tank.

This limited warranty shall be the exclusive warranty made by the Manufacturer and is made in lieu of all other warranties, express or implied, whether written or oral, including, but not limited to warranties of merchantability and fitness for a particular purpose. Manufacturer shall not be liable for incidental, consequential or contingent damages or expenses arising directly or indirectly from any defect in the Tank or the use of the Tank. Manufacturer shall not be liable for any water damage or other damage to property of Owner arising, directly or indirectly, from any defect in the Tank or the use of the Tank.

Manufacturer alone is authorized to make all warranties on Manufacturer's behalf and no statement, warranty or guarantee made by any other party shall be binding on Manufacturer.

Manufacturer shall not be liable for any damage whatsoever relating to or caused by:

- 1. any misuse or neglect of the Tank, any accident to the Tank, any alteration of the Tank, or any other unintended use;
- 2. acts of God and circumstances over which Manufacturer has no control;
- 3. installation of the Tank other than as directed by Manufacturer and other than in accordance with applicable building codes;

- 4. improper installation and/or improper materials used by any installer and not relating to defects in parts or workmanship of Manufacturer;
- 5. failure to maintain the Tank or to operate the Tank in accordance with the Manufacturer's specifications;
- 6. failed components not originally installed by the Manufacturer as a part of the unit at the time of sale;
- 7. exposure to freezing conditions;
- 8. exposure to harmful chemicals, corrosive water, contaminated water, caustic fluids, or liquids harmful to steel tubing, including improperly applied or maintained heat transfer fluids.
- 9. utilizing the Tank as an indirect hot water heater
- 10. connecting the Tank to an open vented heating system or a system that uses piping or components that are permeable to oxygen

Should owner wish to return the Tank to manufacturer for repair or replacement under this warranty, Owner must first secure written authorization from Manufacturer. Owner shall demonstrate proof of purchase, including a purchase date, and shall be responsible for all removal and transportation costs. If Owner cannot demonstrate a purchase date this warranty shall be limited to the period beginning from the date of manufacture stamped on the Tank. Manufacturer reserves the right to deny warranty coverage upon Manufacturer's examination of the Tank. This warranty is restricted to the Owner and cannot be assigned.

Some States and Provinces do not allow the exclusion or limitation of certain warranties. In such cases, the limitations set forth herein may not apply to the Owner. In such cases this warranty shall be limited to the shortest period and lowest damage amounts allowed by law. This warranty gives you specific legal rights and you may also have other rights which vary from State to State or Province to Province.

Owner shall be responsible for all labor and other charges incurred in the removal or repair of the Tank in the field. Please also note that the Tank must be installed in such a manner that if any leak does occur, the flow of water from any leak will not damage the area in which it is installed.

This Warranty is valid for U.S.A. & Canada only. Warranties may vary by country. Please consult your local Stiebel Eltron Representative for the Warranty for your country.

NOTES

NOTES

United States of America

STIEBEL ELTRON, Inc.
17 West Street | West Hatfield, MA 01088
Tel. 413.247.3380 | Fax 413.247.3369
Toll-free 800.582.8423
info@stiebel-eltron-usa.com
www.stiebel-eltron-usa.com

Austria

STIEBEL ELTRON Ges.m.b.H.
Eferdinger Str. 73 | 4600 Wels
Tel. 07242 47367-0 | Fax 07242 47367-42
info@stiebel-eltron.at
www.stiebel-eltron.at

Belgium

STIEBEL ELTRON bvba/sprl
't Hofveld 6 - D1 | 1702 Groot-Bijgaarden
Tel. 02 42322-22 | Fax 02 42322-12
info@stiebel-eltron.be
www.stiebel-eltron.be

Czech Republic

STIEBEL ELTRON spol. s r.o.
K Hájm 946 | 155 00 Praha 5 - Stodůlky
Tel. 251116-111 | Fax 235512-122
info@stiebel-eltron.cz
www.stiebel-eltron.cz

Denmark

Pettinaroli A/S
Mandal Allé 21 | 5500 Middelfart
Tel. 06341 666-6 | Fax 06341 666-0
info@pettinaroli.dk
www.stiebel-eltron.dk

Finland

Insinööritoimisto Olli Andersson Oy
Kapinakuja 1 | 04600 Mäntsälä
Tel. 020 720-9988 | Fax 020 720-9989
info@stiebel-eltron.fi
www.stiebel-eltron.fi

France

STIEBEL ELTRON SAS
7-9, rue des Selliers
B.P 85107 | 57073 Metz-Cédex 3 Tel. 0387
7438-88 | Fax 0387 7468-26
info@stiebel-eltron.fr
www.stiebel-eltron.fr

Germany

STIEBEL ELTRON GmbH & Co. KG
Dr.-Stiebel-Straße | 37603 Holzminden
Tel. 05531 702-0 | Fax 05531 702-480
info@stiebel-eltron.de
www.stiebel-eltron.de

Hungary

STIEBEL ELTRON Kft.
Pacsirtamező u. 41 | 1036 Budapest Tel.
01 250-6055 | Fax 01 368-8097
info@stiebel-eltron.hu
www.stiebel-eltron.hu

Japan

NIHON STIEBEL Co. Ltd.
Ebara building 3F
2-9-3 Hamamatsu-cho
Minato-Ku | 105-0013 Tokyo
Tel. 03 34364662 | Fax 03 34594365
info@nihonstiebel.co.jp
www.nihonstiebel.co.jp

Netherlands

STIEBEL ELTRON Nederland B.V.
Daviottenweg 36
5222 BH 's-Hertogenbosch
Tel. 073 623-0000 | Fax 073 623-1141
stiebel@stiebel-eltron.nl
www.stiebel-eltron.nl

Poland

STIEBEL ELTRON Polska Sp. z o.o. ul.
Instalatorów 9 | 02-237 Warszawa Tel. 022
60920-30 | Fax 022 60920-29
stiebel@stiebel-eltron.com.pl
www.stiebel-eltron.com.pl

Russia

STIEBEL ELTRON LLC RUSSIA
Urzhumskaya street 4,
building 2 | 129343 Moscow
Tel. 0495 7753889 | Fax 0495 7753887
info@stiebel-eltron.ru
www.stiebel-eltron.ru

Slovakia

STIEBEL ELTRON Slovakia, s.r.o.
Hlavná 1 | 058 01 Poprad
Tel. 052 7127-125 | Fax 052 7127-148
info@stiebel-eltron.sk
www.stiebel-eltron.sk

Sweden

STENERGY
Vasagatan 14 | 545 30 Töreboda
Sales:
Tel. 0506 105-10 | info@stiebel-eltron.se
Technique & Service:
Tel. 0150 54200 | info@heatech.se
www.stiebel-eltron.se

Switzerland

STIEBEL ELTRON AG
Netzibodenstr. 23 c | 4133 Pratteln
Tel. 061 81693-33 | Fax 061 81693-44
info@stiebel-eltron.ch
www.stiebel-eltron.ch

Thailand

STIEBEL ELTRON Asia Ltd.
469 Moo 2 Tambol Klong-Jik
Amphur Bangpa-In | 13160 Ayutthaya
Tel. 035 220088 | Fax 035 221188
info@stiebel-eltronasia.com
www.stiebel-eltronasia.com

United Kingdom and Ireland

STIEBEL ELTRON UK Ltd.
Unit 12 Stadium Court
Stadium Road | CH62 3RP Bromborough
Tel. 0151 346-2300 | Fax 0151 334-2913
info@stiebel-eltron.co.uk
www.stiebel-eltron.co.uk

STIEBEL ELTRON

Irrtum und technische Änderungen vorbehalten! | Subject to errors and technical changes! | Sous réserve d'erreurs et de modifications techniques! | Onder voorbehoud van vergissingen en technische wijzigingen! | Salvo error o modificación técnica! | Rätt till misstag och tekniska ändringar förbehålls! | Excepto erro ou alteração técnica | Zastrzeżone zmiany techniczne i ewentualne błędy | Omyly a technické změny jsou vyhrazeny! | A muszáki változtatások és tévedések jogát fenntartjuk! | Отсутствие ошибок не гарантируется. Возможны технические изменения. | Chyby a technické zmeny sú vyhradené! Stand 8643