

CNS Trend & Plus Wall-Mounted Convection Heaters

Engineer/Architect: _____ **Date:** _____

Job Name/Customer: _____ **Phone:** _____

Location: _____ **Date Required:** _____

Contractor: _____ **Phone:** _____

Heater Specifications	Item No.	Quantity	kW	Voltage	Amperage
Model # CNS Trend/Plus _____	_____	_____	_____	_____	_____

Description

CNS Trend/Plus are surface-mounted convection heaters that can be used as a replacement for traditional baseboard heaters or as a stand-alone heating system. The built-in thermostat can be used to control a single CNS or multiple CNS units can be placed strategically in larger spaces and their temperature settings adjusted individually. CNS Plus heaters feature a backlit digital thermostat/display. CNS heaters may be wired to use an existing wall-mounted thermostat. CNS is designed with a frost protection setting; the lowest setting will maintain a room above freezing temperature. Overheat protection is built into the unit. The external casing of the appliance is made from stove enameled sheet steel with some plastic trim pieces. Controls are located on top right looking at the appliance. Color is Alpine White.

Specifications

Model	CNS 100-1 Trend	CNS 150-2 Trend	CNS 100-1 Plus	CNS 150-1 Plus	CNS 100-2 Plus	CNS 150-2 Plus	CNS 200-2 Plus	CNS 300-2 Plus
Item number	201991	201992	201994	201996	201997	201998	201999	202000
Voltage	120 v	240 v or 208 v	120 v	120 v	240 v or 208 v	240 v or 208 v	240 v or 208 v	240 v or 208 v
Wattage	1000 w	1500 w 1125 w	1000 w	1500 w	1000 w 750 w	1500 w 1125 w	2000 w 1500 w	3000 w 2250 w
Amperage	8.3 A	6.3 A 5.4 A	8.3 A	12.5 A	4.2 A 3.6 A	6.3 A 5.4 A	8.3 A 7.2 A	12.5 A 10.8 A
Btu/hr	3412	5118 3839	3412	5118	3412 2559	5118 3839	6824 5118	10236 7677
Electrical connection	Power cord with plug, hard-wired connection possible	Junction box, rear	Power cord with plug, hard-wired connection possible	Power cord with plug, hard-wired connection possible	Junction box, rear	Junction box, rear	Junction box, rear	Junction box, rear
Required circuit breaker size¹	15 A	10 A	15 A	15 A	10 A	10 A	15 A	15 A
Required wire size (copper)	14 AWG	14 AWG	14 AWG	14 AWG	14 AWG	14 AWG	14 AWG	14 AWG
Temperature range	41 °F–86 °F (5 °C–30 °C)							
Frost protection setting	45 °F (7 °C)							
Height	17¾" (450 mm)							
Width	16¾" (426 mm)	22 ¹⁵ / ₁₆ " (582 mm)	16¾" (426 mm)	22 ¹⁵ / ₁₆ " (582 mm)	16¾" (426 mm)	22 ¹⁵ / ₁₆ " (582 mm)	29 ¹ / ₁₆ " (738 mm)	41 ⁵ / ₁₆ " (1050 mm)
Depth	3 ¹⁵ / ₁₆ " (100 mm)							
Weight	10.1 lb (4.6 kg)	13.2 lb (6.0 kg)	10.1 lb (4.6 kg)	13.2 lb (6.0 kg)	10.1 lb (4.6 kg)	13.2 lb (6.0 kg)	17.0 lb (7.7 kg)	24.0 lb (10.9 kg)
Room size estimate²	100 sq.ft	150 sq.ft.	100 sq.ft	150 sq.ft.	100 sq.ft.	150 sq.ft.	200 sq.ft.	300 sq.ft.

¹ This is our recommendation as the manufacturer. Check local codes for compliance if necessary.

² Based on average insulation

rev. 8.2022 Due to our continuous process of engineering and technological advancement, specifications may change without notice.

Dimensions & clearances

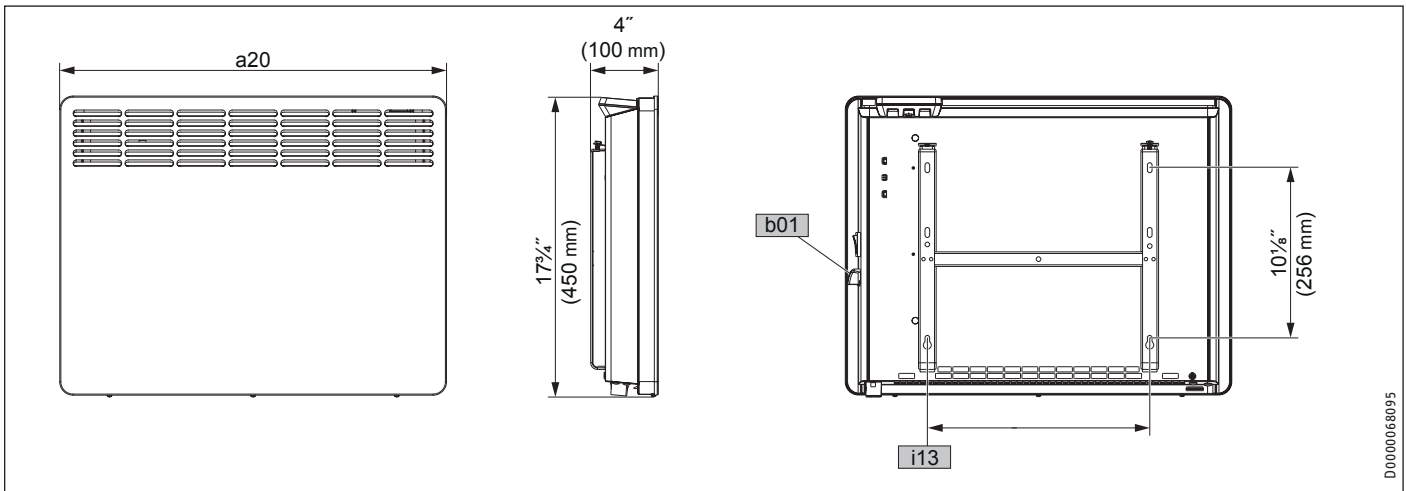

		CNS 100-1 Trend CNS 100-1 Plus CNS 100-2 Plus	CNS 150-1 Plus CNS 150-2 Trend CNS 150-2 Plus	CNS 200-2 Plus	CNS 300-2 Plus
a20	Heater Width	16 3/4" (426 mm)	22 15/16" (582 mm)	29 1/16" (738 mm)	41 5/16" (1050 mm)
b01	Electrical cable entry				
i13	Wall mounting bracket Horizontal hole spacing	7 1/16" (179 mm)	13 3/16" (335 mm)	19 5/16" (491 mm)	31 5/8" (803 mm)



Conforms to ANSI/UL Std. 1278
Certified to CAN/CSA Std. 22.2 No. 46



Warranty

Residential & commercial warranty: Stiebel Eltron warrants to the original owner that the CNS Trend or CNS Plus convection heater will be free from defects in workmanship and materials for a period of three (3) years from the date of purchase. Should the part(s) prove to be defective under normal use during this period, Stiebel Eltron, Inc. will be responsible for replacement of the defective part(s) only. Stiebel Eltron, Inc. is not responsible for labor charges to remove and/or replace the defective part(s), or any incidental or consequential expenses. Should the owner wish to return the convection heater for repair, the owner must first secure written authorization from Stiebel Eltron, Inc. The owner shall be required to show proof of purchase date, and to pay all transportation costs to return the defective part(s) or convection heater for repair or replacement. Warranty is void if water heater has been installed or used improperly or if design has been altered in any way.