

MegaBoost Tankless Electric Water Heater Booster

Engineer/Architect: _____ **Date:** _____
Job Name/Customer: _____ **Phone:** _____
Location: _____ **Date Required:** _____
Installed on: Cold inlet side of tank Hot outlet side of tank **Tank Size:** _____ gallons
Contractor: _____ **Phone:** _____

Specifications	Item No.	Quantity	kW	Voltage	Amperage
Model # MegaBoost _____	_____	_____	_____	_____	_____

Applications

Commercial › Industrial › Institutional

- › Office Buildings
- › Stores
- › Malls
- › Warehouses
- › Restaurants
- › Gas Stations
- › Schools
- › Hotels / Motels
- › Commercial Condominiums
- › Manufacturing Facilities

Residential

- › Bathroom Sinks
- › Kitchen Sinks
- › Laundry Areas
- › Cabins / Cottages
- › Low Flow Showers



Specifications

Model	Phase	Voltage	kW	Amps	Circuit Breaker	Minimum Wire Size
MegaBoost	single	240 V	9.6	40	40	8/2 AWG
	single	208 V	7.2	35	35	8/2 AWG

Model	MegaBoost
Part number	524201
Weight	5.9 lbs / 2.7 kg
Min. flow to activate	0.264 gpm / 1.0 l/min
Max. inlet water temp.	131°F / 55°C.
Operating Pressure	Min. 30 psi, Max. 150 psi
Cover	White ABS

Dimensions

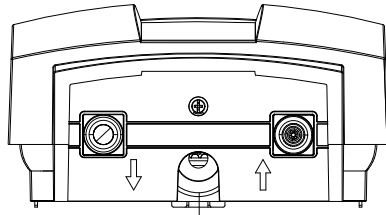

Electrical cable entry

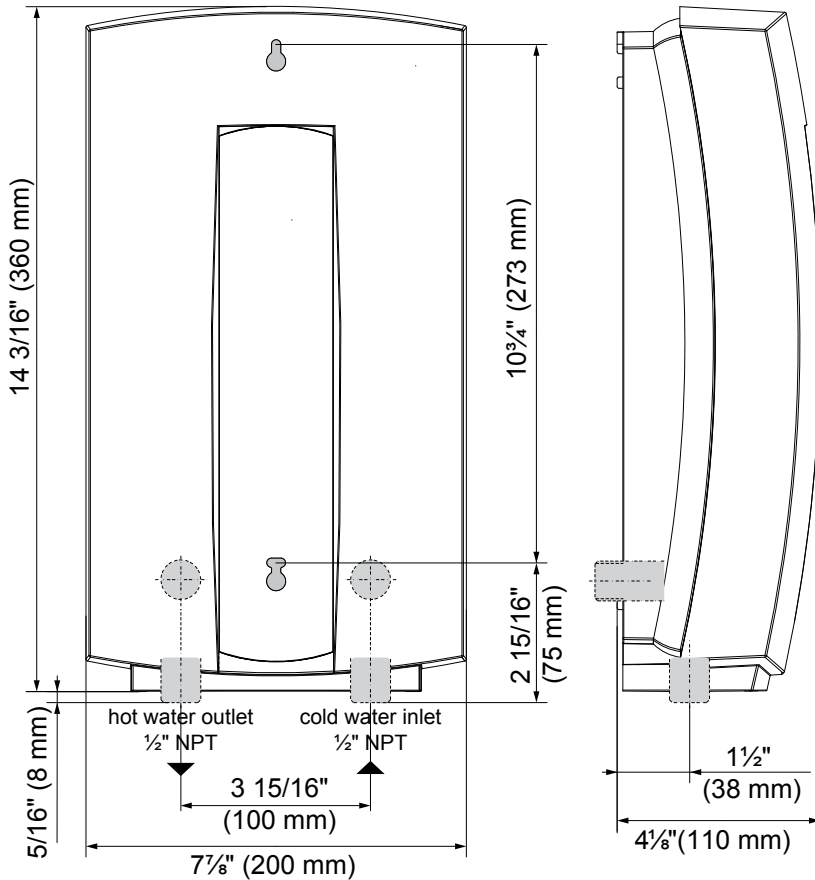

Intertek
84335

Certified to ANSI/UL Std. 499
Conforms to CAN/CSA
Std. C22.2 No. 64



Tested and certified by WQA
against NSF/ANSI 372
for lead free compliance.

ISO 9001
CERTIFIED



Warranty

Residential & commercial warranty: Stiebel Eltron, Inc. warrants to the original owner that the MegaBoost tankless electric water heater will be free from defects in workmanship and materials for a period of three (3) years from the date of purchase, and free from leak age for a period of seven (7) years from the date of purchase. Should the part(s) prove to be defective under normal use during this period, Stiebel Eltron, Inc. will be responsible for replacement of the defective part(s) only. Stiebel Eltron, Inc. is not responsible for labor charges to remove and/or replace the defective part(s), or any incidental or consequential expenses. Should the owner wish to return the tankless electric water heater for repair, the owner must first secure written authorization from Stiebel Eltron, Inc. The owner shall be required to show proof of purchase date, and to pay all transportation costs to return the defective part(s) or tankless electric water heater for repair or replacement. Warranty is void if water heater has been installed or used improperly or if design has been altered in any way.